

1 LOCAÇÃO SAPATA/PILAR/V. BALDRAME
ESCALA: 1:50

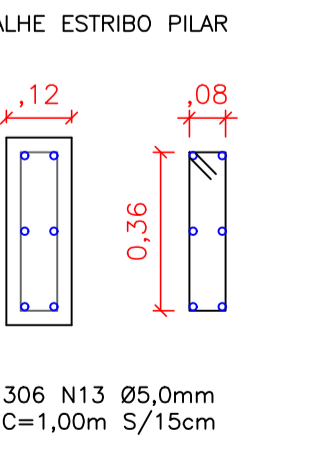
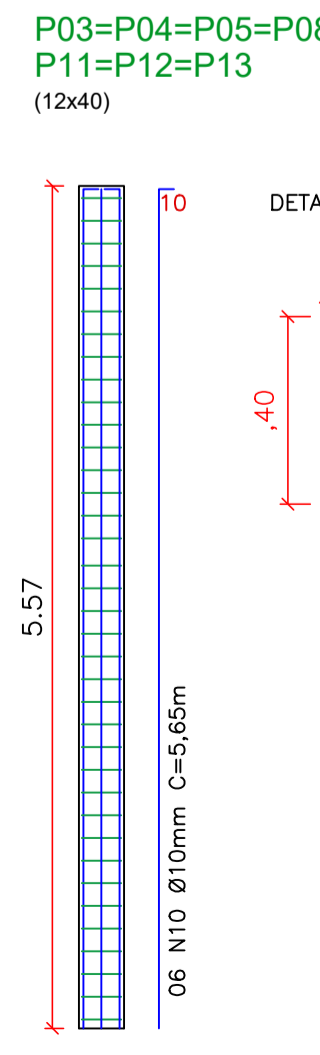
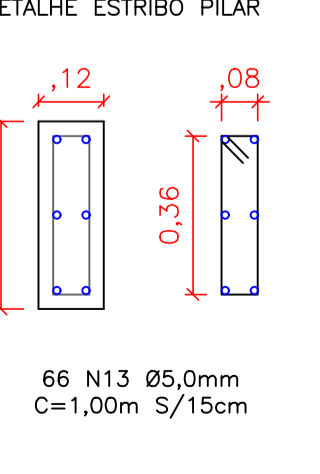
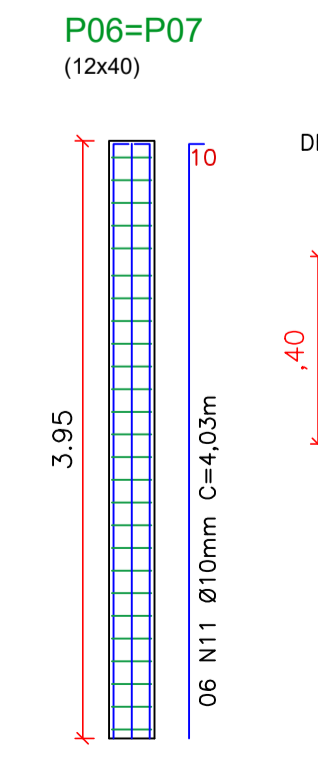
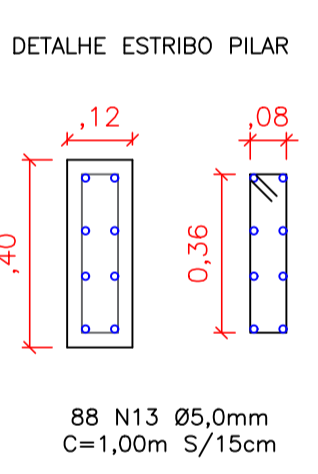
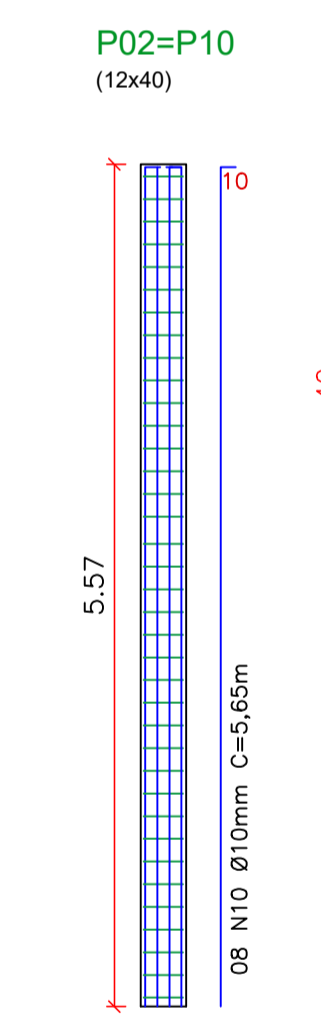
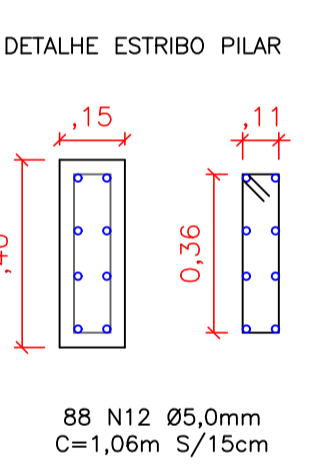
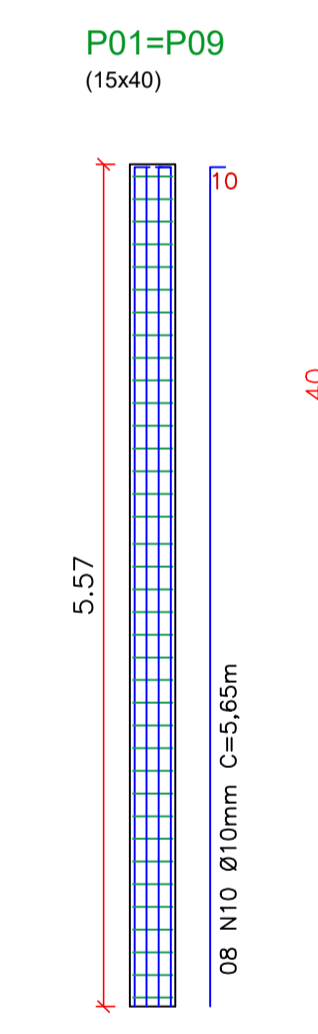
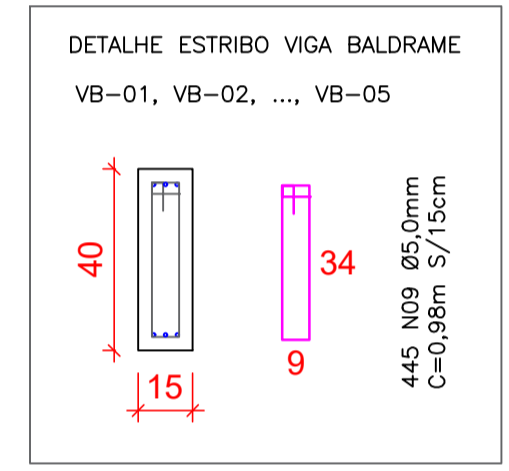
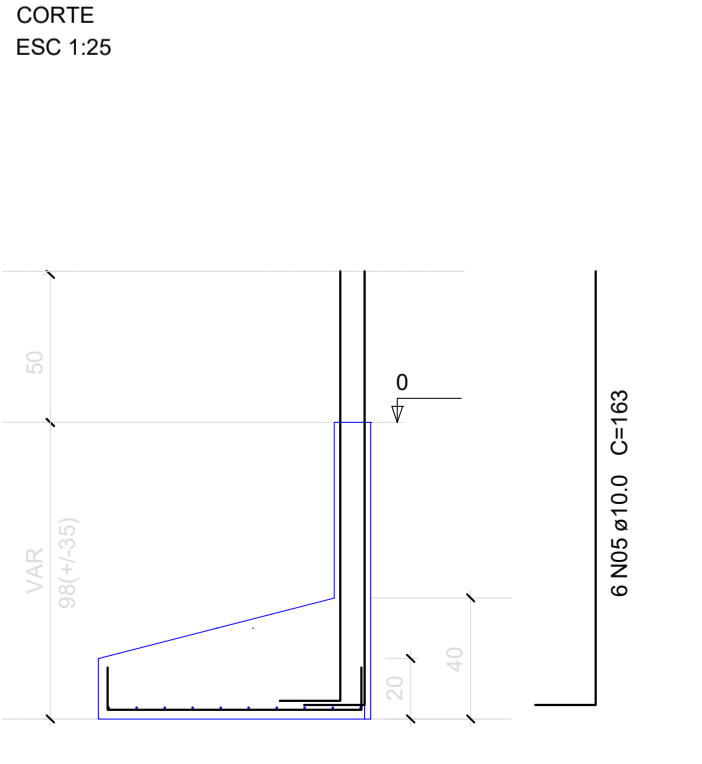
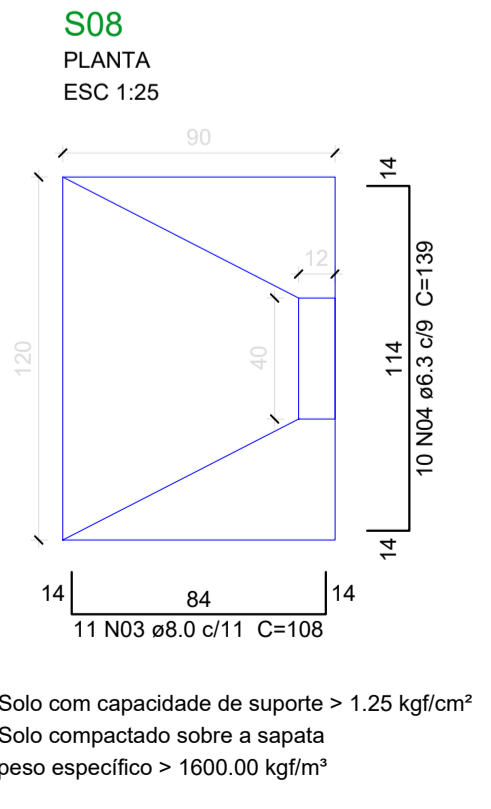
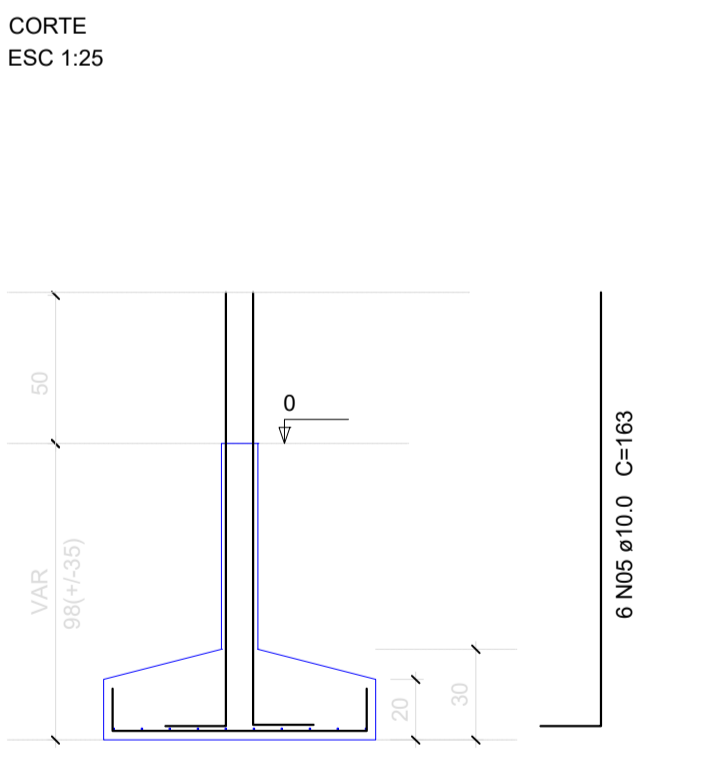
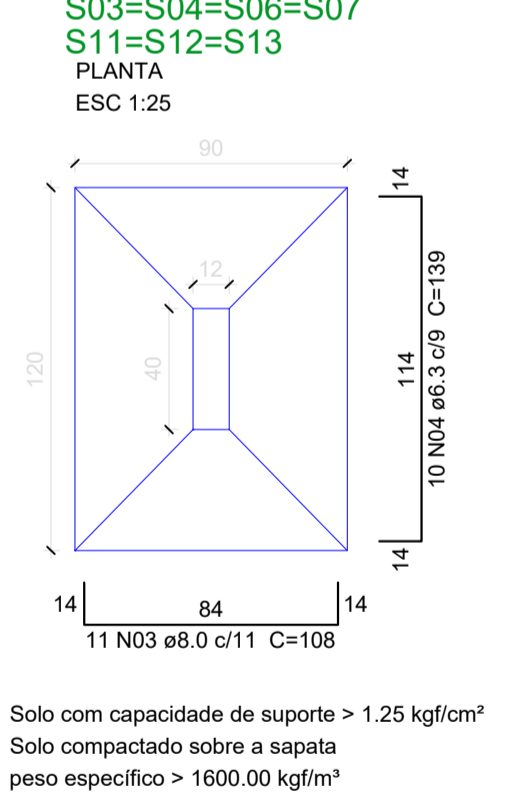
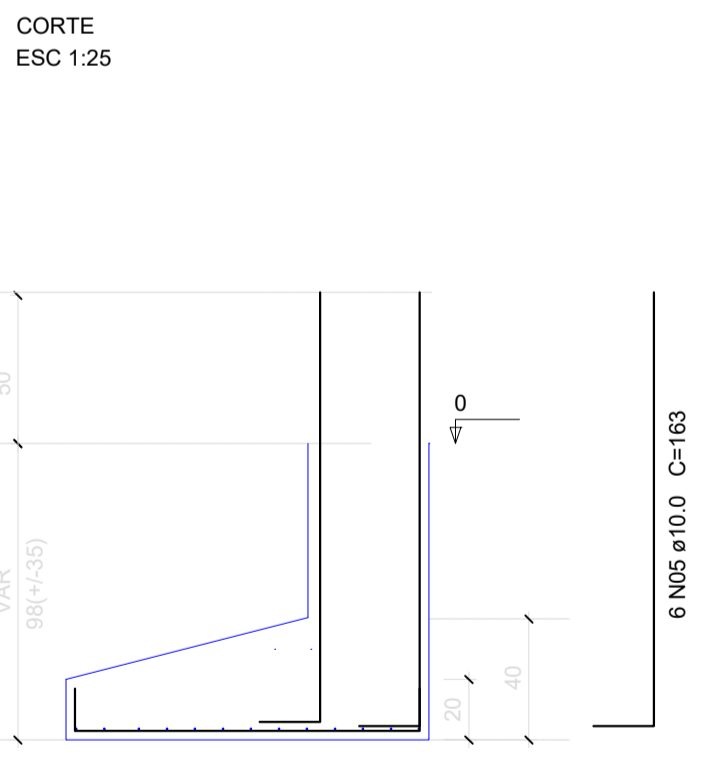
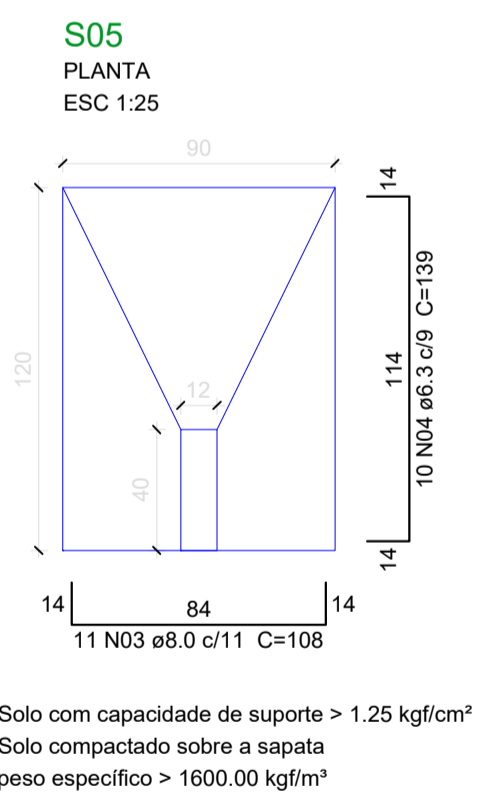
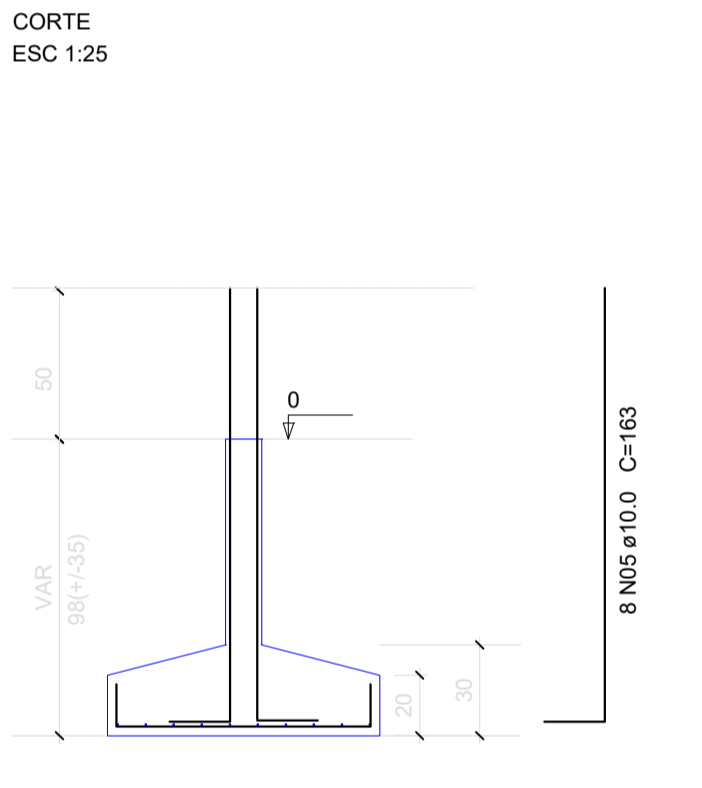
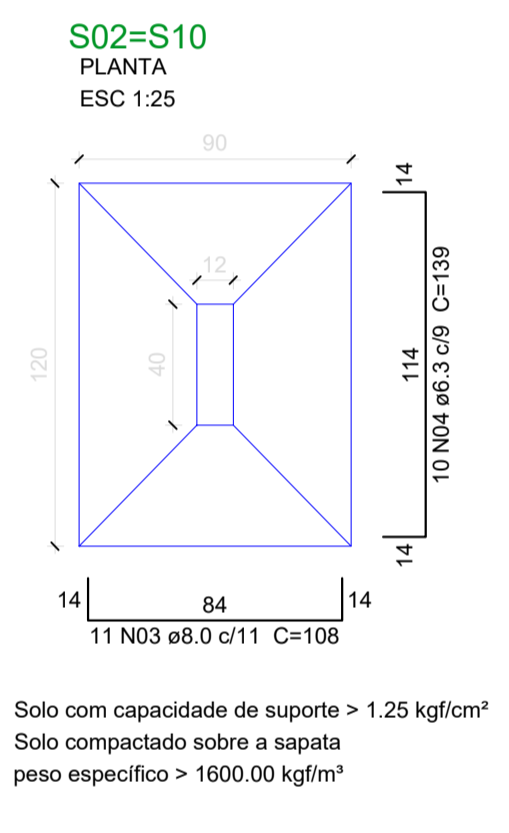
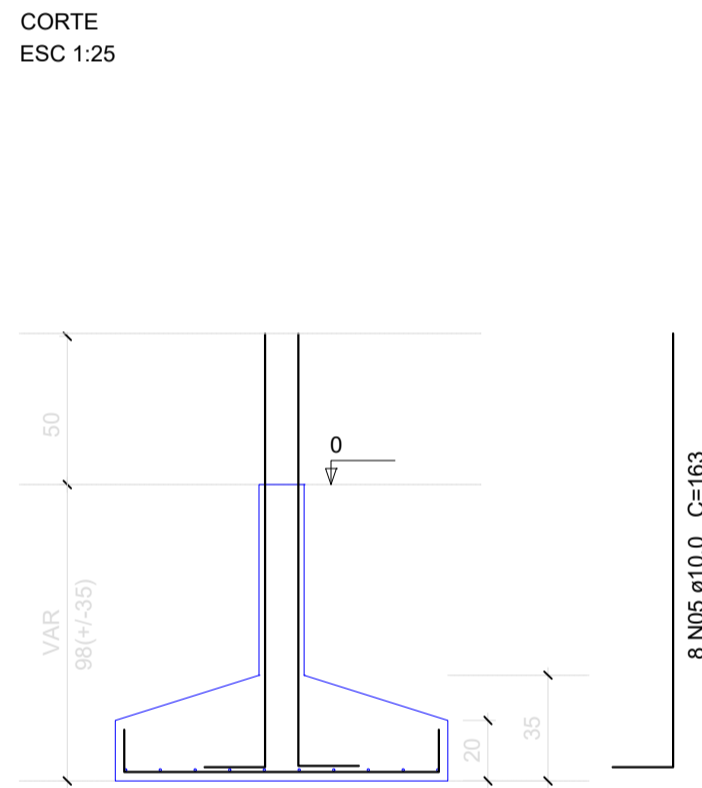
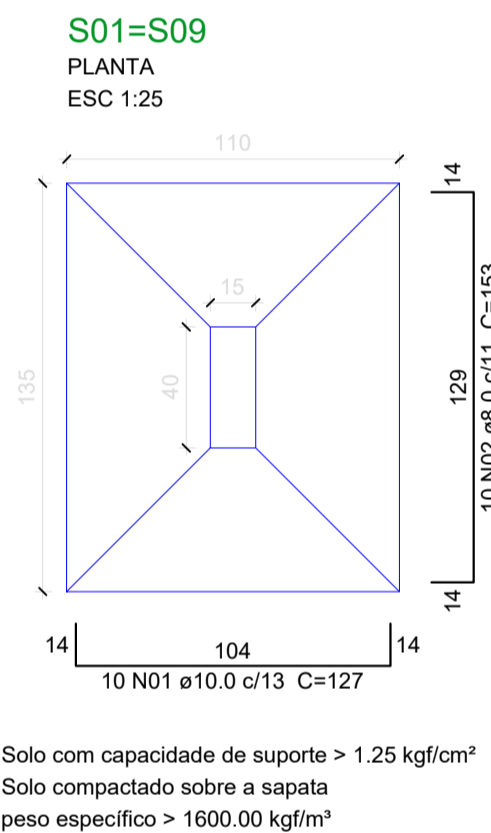

Legenda dos Pilares

- Pilar que morre
- Pilar que passa
- Pilar que nasce

POSICÃO	Ø (mm)	QTD.	COMPRIMENTO	
			UNIT.	TOTAL
N1	10.0	20	1.27	25.40
N2	8.0	20	1.53	30.60
N3	8.0	121	1.08	130.68
N4	6.3	110	1.39	152.90
N5	10.0	86	1.63	140.18
N6	10.0	12	12.00	144.00
N7	10.0	12	6.10	73.20
N8	10.0	18	7.13	128.34
N9	5.0	452	0.92	415.59
N10	10.0	74	5.65	418.10
N11	10.0	12	4.03	48.36
N12	5.0	88	1.06	92.86
N13	5.0	460	1.00	460.00
N33	10.0	4	5.44	21.76

RESUMO FERRAGENS			
Ø (mm)	COMPRIMENTO TOTAL (m)	Kg/m	Kg TOTAL
5.0	968.45	0.154	149.14
6.3	152.90	0.245	37.46
8.0	161.28	0.395	63.71
10.0	999.34	0.617	616.59

CAMARA MUNICIPAL DE MINAÇU-GO

ESTRUTURAL

PROPRIETARIO: CÂMARA MUNICIPAL DE MINAÇU
CNPJ:01.650.018/0001-00

RESPONSÁVEL TÉCNICO: Gustavo Torres de Souza
Eng. Civil - CREA: 1016152728/D-GO

REVISÃO:

DADOS DA OBRA:
- Endereço: AV. CEARÁ QD.01 CONJUNTO HABITACIONAL PRIMAVERA - MINAÇU / GO
- Quadro de medidas:
Área Lote: 5.102,00m²
Área Construída Existente: 612,05m²
Área a Construir: 163,16m²
Área Construída Total: 775,21m²
Taxa de Ocupação: 15,19%

DATA: AGOSTO/2022 ESCALA: INDICADA

CONTEUDO:
- Locação Sapata/V. Baldrame;
- Locação Pilar;
- Detalhe Sapata;
- Detalhe Pilar;
- Detalhe Viga Baldrame;
- Tabela;
- Notas.

APROVAÇÕES: